

# ACTUATORS



## AND ACCESSORIES

Two position valves switch back and forth between Load and Inject, or Position A and Position B. Selectors operate in continuous revolutions by incremental steps. There are several ways to actuate each type of valve, along with a number of supporting controllers and devices to interface the actuators with computer-controlled systems.

With the exception of low pressure Cheminert selectors, we recommend that selectors be purchased with air or electric actuators. While a manual detent assembly is available, the higher turning torque of our other selector designs makes them more difficult to position accurately by hand.

### ELECTRIC ACTUATION

#### UNIVERSAL ACTUATOR

The universal actuator operates virtually any Valco or Cheminert rotary valve – two position and selector alike – greatly simplifying the electronic aspect of instrument design. A manual controller is included; current interface options include RS232/485, USB, and BCD.

Universal actuator .....pages 174-175

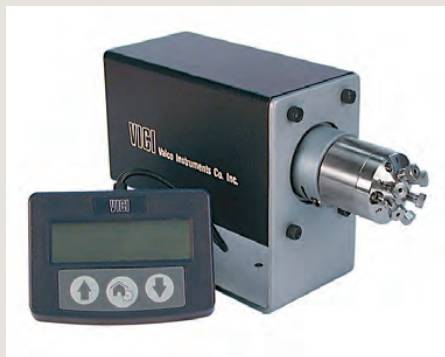

#### MICROELECTRIC ACTUATOR

The microelectric actuator features automatic valve alignment, high-speed switching, compact size, 24 VDC power input, and reversible direction (in the selector model).

Microelectric actuators can be operated manually via a controller with toggle switch and position-indicating LEDs, or can be connected to an external data system for fully automated control. Built-in multidrop RS-232 (RS-485 optional) facilitates bidirectional communications.

Two position ..... page 176  
Selector .....176





## AIR ACTUATION

Air actuators are useful in situations where any spark could be disastrous or where there is no electricity available. They are small, relatively inexpensive, very rugged and dependable, and field-serviceable. Low gas consumption and light-weight, compact construction make the air actuator suitable for aerospace flight hardware applications as well as laboratory or process applications.

With the addition of a DVI (digital valve interface) to translate the timed event signals into the necessary air pulses, air actuators



can be automatically switched by a data system, integrator, or controller.

Two position ..... page 179  
Selector ..... 178

## MANUAL ACTUATION

Simplicity and low cost are the main advantages of manual actuation. Some models can be ordered with position feedback, an option which sends a signal to start a data system when the valve is switched.

Manual knobs and handles ..... page 190  
Position feedback ..... 181



## SEE ALSO

### Actuators

Air ..... pages 178-179  
Universal electric. .... 174-175  
Microelectric. .... 176

### Controllers and Accessories

V-SV-S52 4-way solenoid air valve ..... 180  
DVI Digital valve interface ..... 181  
HSSA High speed switching accessory ..... 182  
V-SV-S53 5-way three position solenoid  
air valve ..... 180  
PFAF Position feedback for air actuators ... 181  
RAD Right angle drive. .... 186

### Mounting Hardware

Closemount assembly. .... 190  
Standoff assembly ..... 187-189

## STANDOFF ASSEMBLIES

All valves, no matter what their actuation mode, can be ordered with a standoff assembly.

The standoff is an extension shaft mounted between the handle or actuator and the valve, allowing the valve to be installed within a heated zone while the actuator or handle remains outside at ambient temperature. The standoff extends through the oven wall, and is secured by a clamp ring supplied with the assembly. Standard standoff assembly lengths are 2", 3", 4", and 6". Other lengths can be special-ordered at additional cost.

Standoff assemblies ..... page 187

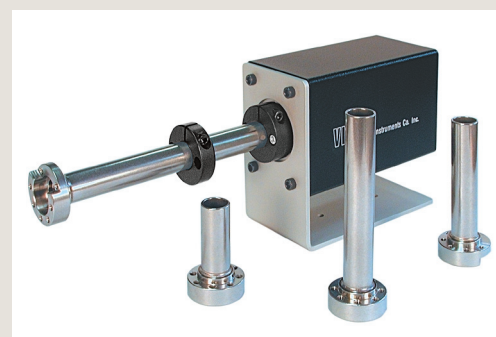



## UNIVERSAL ACTUATORS

- CE certified
- One actuator works with two position valves *and* selectors
- Simplified, universal communication protocol
- Variety of interfaces
- Three versions for various valve torque requirements

Three universal actuator models – high speed, medium speed/medium torque, and high torque – cover our entire line of Valco and Cheminert valves and selectors, with their wide range of turning torques.

Actuators include a universal 24 VDC power supply and a manual controller. An OEM version that excludes these items is also available. The standard interface allows simple positioning commands – Step and Home for selectors, A and B for two position – via direct input signals from switch closures, relay contacts, or TTL-compatible interfaces. A more extensive command set is available with the optional RS-232, RS-485, USB, or BCD interfaces.

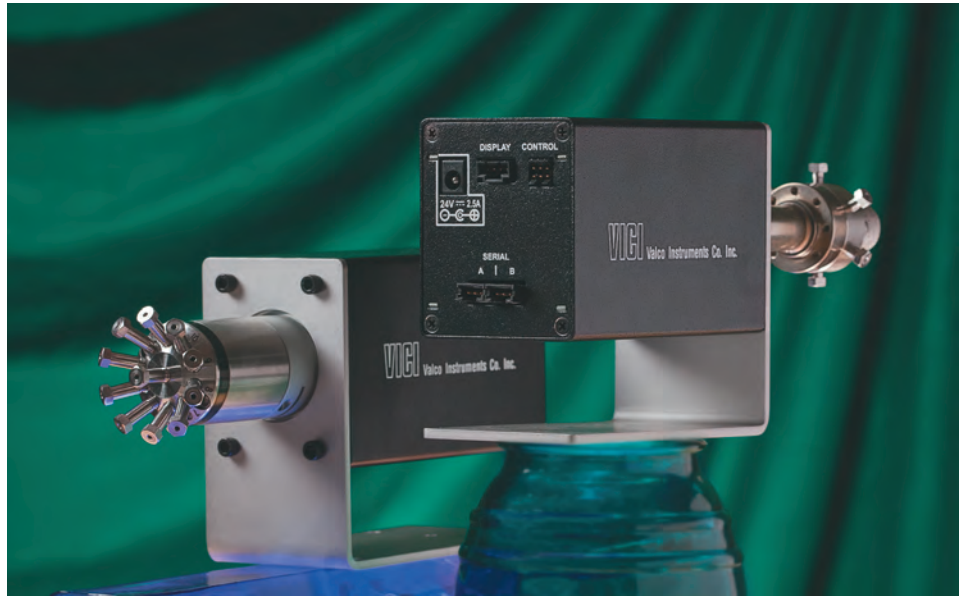

### Universal actuators

Standard voltage 24 VDC. Includes autosensing 24 VDC power supply. Does not include mounting hardware. Order separately.

Interface	High speed (EUH)	Medium torque (EUD)	High torque (EUT)
	Prod no	Prod no	Prod no
Standard	EUH	EUD	EUT
RS-232 *	EUHA	EUDA	EUTA
RS-485 *	EUHF	EUDF	EUTF
USB	EUHB	EUIDB	EUTB
BCD	EUHC	EUDC	EUTC

\*Actuators ordered with a serial interface come with a switchable 232/485 board. If ordered with suffix A, switch will be preset for RS-232. If ordered with suffix F, switch will be preset for RS-485.

#### **i** HARDWARE NOTE

While the actuators are universal, the valve mounting hardware is not. The product numbers shown do not include the hardware required for mounting a valve, since the necessary hardware depends on the valve type.

- If you are ordering the actuator for use with an **existing valve**, call our sales or technical staff to determine the correct hardware needed.
- If you want to order the universal actuator with a **new valve**, simply use the product number in the valve chart and we'll provide the correct hardware.

#### **i** KEYED STANDOFFS FOR SELECTORS

Keyed standoff assemblies are used with selectors on universal and microelectric actuators, to key the valve body to the actuator and standoff so that the actuators can self-align and operate valves with any number of positions.

Valco selectors are not keyed unless ordered with a universal or microelectric actuator. To install an actuator on an existing Valco selector, the key (pin) must be removed from the actuator clamp ring assembly. This can be done easily with a pair of pliers.

See page 189, top and bottom illustrations, for drawings of keyed standoff assemblies with microelectric actuators.

#### **➔** MORE INFO

Microelectric actuators . . . . . 176

#### **➔** MOUNTING HARDWARE

Closemount hardware . . . . . page 190  
 Right angle drive . . . . . 186  
 Standoff assemblies . . 187  
 Standoff mounting hardware . . . . . 187



**CHEMINERT UHPLC INJECTOR**  
on universal actuator



**CHEMINERT LC INJECTOR**  
on universal actuator



**VALCO GC INJECTOR**  
on universal actuator

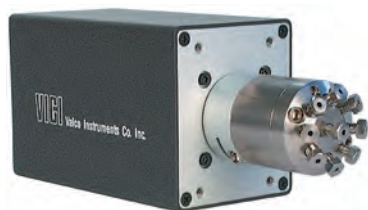

**CHEMINERT HPLC SELECTOR**  
on universal actuator

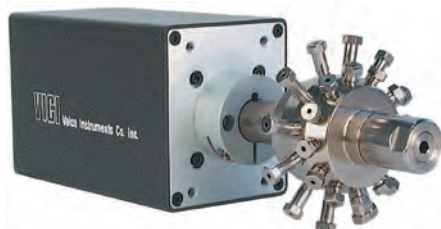

**VALCO GC SELECTOR**  
on universal actuator

**? WHICH MODEL FOR WHICH INJECTOR/TWO POSITION VALVE?**

Fitting size	VALCO GC		VALCO HPLC	
	Bore size	Actuator model	Bore size	Actuator model
1/32"	0.25 mm	EUH	—	—
1/16"	0.40 mm	EUH	0.40 mm	EUH
1/16"	0.75 mm	EUD	0.75 mm	EUD
1/8"	0.75 mm	EUD	0.75 mm	EUD
1/4"	4.0 mm	EUT	—	—

CHEMINERT	HPLC	UHPLC	Low Pressure
	Actuator model	Actuator model	Actuator model
4 and 6 ports *	EUH	EUH *	EUH
8 and 10 ports	EUH	EUD	EUH

\* 20,000 psi UHPLC versions use EUD.

**? WHICH MODEL FOR WHICH SELECTOR?**

VALCO	Actuator model
All valves	EUT

CHEMINERT	HPLC	UHPLC
	Actuator model	Actuator model
4 and 6 ports *	EUH	EUH *
8 and 10 ports	EUD	EUD

\* 20,000 psi versions use EUD.

CHEMINERT	Low Pressure	
	Model	Actuator model
Model C25	page 159	EUH
Model C25Z	page 158	EUH
Model C25G	page 160	EUT
Model C45R	page 161	EUT



## MICROELECTRIC ACTUATORS

- CE certified
- Optional position indication
- Compact stepper motor design
- Automatic self-alignment with keyed selector valves
- Variety of control modes with optional interfaces
  - Step and home functions with contact closure (*standard*)
  - Direct position access via BCD interface
  - Position access/confirmation via serial interface



One multiposition actuator can be used on any selector, from 2 to 96 positions, so you can stock only one type of actuator even if you have 4, 6, 8, 10, 12, and 16 position valves. Valve position memory is maintained even in the event of a power failure.

The direction reversal feature means that if a 6 position stream selection valve is on stream 1 and you select stream 6, you have the option of stepping "backwards" to stream 6 instead of passing through 2, 3, 4, and 5. The RS-232 input offers various commands like position access, direction control, shortest route, etc. (The RS-232 cable must be ordered separately. *See page opposite.*)

The two position microelectric actuator features exclusive stall-sensing circuitry which eliminates problems associated with valve/actuator misalignment. This means that you can stock one actuator for valves that turn 30°, 36°, 45°, 60°, 90°, or anything in between.

An actuator can be specified with closemount hardware, with a standoff, or with just the standoff mounting hardware, if your valve already has a standoff.

Microelectric actuators are designed for room temperature use. Valves mounted in ovens require a standoff assembly, which locates the actuator out of the heated zone.

### Microelectric actuators

#### FOR TWO POSITION VALVES

Standard voltage 24 VDC. Includes autosensing 24 VDC power supply. Consult the charts at right to determine which actuator model is best suited for your valve.

Description	w/closemount assembly Prod no	w/2" standoff assembly Prod no	For use with existing standoff Prod no
Highest speed actuator	EQ	EQ2	EQS
High speed actuator	EH	EH2	EHS
Medium torque actuator	EP	EP2	EPS
High torque actuator	ED	ED2	EDS
Highest torque actuator	ET	ET2	ETS

### Microelectric actuators

#### FOR SELECTORS

Standard voltage 24 VDC. Includes autosensing 24 VDC power supply.

Description	w/keyed closemount assembly Prod no	w/keyed 2" standoff assembly Prod no	For use with existing standoff Prod no
High speed actuator	EMH	EMH2	EMHS
High torque actuator	EMT	EMT2	EMTS

### ? WHICH MODEL FOR WHICH INJECTOR/TWO POSITION VALVE?

VALCO Fitting size	GC Bore size	HPLC Actuator model	HPLC Actuator model
1/32"	0.25 mm	EH	EP
1/16"	0.40 mm	EH	EP
1/16"	0.75 mm	ED	ED
1/8"	0.75 mm	ED	ED
1/4"	4.0 mm	ET	—

#### CHEMINERT Actuator model

C74X, 8 & port *	ED
All other valves	EH

### ? WHICH MODEL FOR WHICH SELECTOR?

VALCO	Actuator model
All valves	EMT

CHEMINERT	HPLC Actuator model	UHPLC Actuator model
4 and 6 ports *	EMH	EMH *
8 and 10 ports	EMD	EMD

\* 20,000 psi versions use EMD.

CHEMINERT	Low Pressure
Model C25	page 159
Model C25Z	page 158
Model C25G	page 160
Model C45R	page 161



Universal actuators . . . . . 174-175



**i DAISY CHAIN CABLES**

Daisy chain cables permit a single serial port (RS-232/485) to control multiple actuators – newer two position microelectric and universal. See Technical Note 421 for further information.

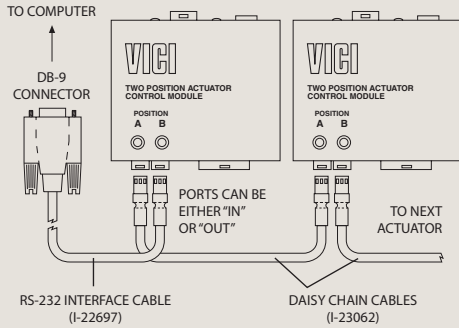

**Daisy chain cables**

FOR UNIVERSAL AND MICROELECTRIC ACTUATORS

- More layout flexibility
- Economical

Microelectric and universal actuators with the RS-232/485 interface option can be daisy-chained for control from a single serial port. A chain of actuators requires only one RS-232/485 interface cable, plus a 3-pin daisy chain cable for each additional actuator.

Note that for reliable RS-232 communication, cables should be no longer than one meter; longer lengths can affect the signal integrity. The RS-485 protocol provides reliable communication over longer lengths.

Length	Protocol	Prod No
55 cm (22")	RS-232/485	I-23062
1 m (39")	RS-232/485	I-23062-3.3
1.5 m (5')	RS-485	I-23062-5
3 m (10')	RS-485	I-23062-10
6 m (20')	RS-485	I-23062-20

**RS-232/485 interface cable**

	Prod No
RS-232/485 interface cable	I-22697

**Plug-and-play cables**

FOR UNIVERSAL AND MICROELECTRIC ACTUATORS

Plug-and-play cables will allow a direct connection and control between a specific instrument and a microelectric or universal actuator. Contact technical support for other instruments.

		Prod No	
BCD cable	Microelectric or universal actuator to	Agilent 6890 GC	V-EMPMCR-HP6890
		Agilent 6890 Network GC	V-EMPMCR-HP6890N
		Agilent 7890 GC	V-EMPMCR-HP6890N
<b>For 4 and 6 column selector * (page 157)</b>			
Remote cable	Microelectric or universal actuator to	Agilent 1100/1200 LC	V-EMPMCR-HP1100
		Waters Alliance LC	V-EMPMCR-WA2690
<b>For 8 and 10 column selector * (page 157)</b>			
Remote cable	Microelectric or universal actuator to	Agilent 1100 LC	V-EMPMCR-HP1100-10
		Waters Alliance LC	V-EMPMCR-WA2690-10

\* Requires a specific software setting in the actuator control module

**➔ MOUNTING HARDWARE**

Closemount hardware . . . . . page 190  
 Right angle drive . . . . . 186  
 Standoff assemblies . . 187  
 Standoff mounting hardware . . . . . 187



## AIR ACTUATORS

Air actuators offer reliable performance under the most stringent conditions. Low gas consumption and lightweight, compact construction make the air actuator suitable for aerospace flight hardware applications as well as laboratory or process applications.

The standard air actuator is rated for up to 80 psig at temperatures up to 70°C. Generally speaking, valves which will be heated require a standoff assembly, which locates the air actuator out of the heated zone and supports both the valve and actuator. A high temperature model permits both valve and actuator to be mounted within an oven (175°C maximum), but it is not recommended for use below 50°C.

## AIR ACTUATORS FOR SELECTORS

The recommended method for implementing a selector (multi-position) air actuator requires only a single 4-way solenoid. Up to 80 psig may be used without damaging the valve or actuator. Bottled instrument air or nitrogen is recommended.

If plant air from compressors must be used, an oil separator and water dryer are required.

Multiposition air actuators include a rotary switch which may be connected to a digital readout of your own design.



### Standard air actuators

#### FOR SELECTORS

Temperature range 0-70°C  
Standoff version includes a 2" standoff. 3", 4", and 6" standoffs are also available.

	With closemount assembly <i>Prod No</i>	With 2" standoff assembly <i>Prod No</i>	With standoff mounting hardware <i>Prod No</i>
4 position	A4	A42	A4S
6 position	A6	A62	A6S
8 position	A8	A82	A8S
10 position	A10	A102	A10S
12 position	A12	A122	A12S
16 position	A16	A162	A16S

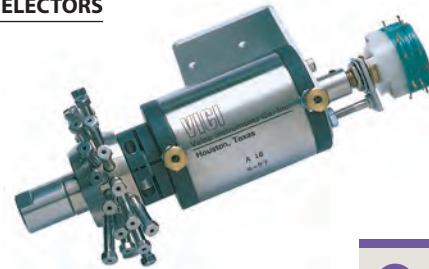

### High temperature air actuators

#### FOR SELECTORS

Temperature range 50-175°C  
Standoff version includes a 4" standoff. 2", 3", and 6" standoffs are also available.

	With closemount assembly <i>Prod No</i>	With 4" standoff assembly <i>Prod No</i>	With standoff mounting hardware <i>Prod No</i>
4 position	AT4	AT44	AT4S
6 position	AT6	AT64	AT6S
8 position	AT8	AT84	AT8S
10 position	AT10	AT104	AT10S
12 position	AT12	AT124	AT12S
16 position	AT16	AT164	AT16S

## Replacement O-rings

Includes a complete set of O-rings for a multiposition air actuator.

	<i>Prod No</i>
Standard	ORMP
High temp	ORTMP



### **t** TECH TIP

The actuator's rotation must be properly matched to the valve's. If you are converting a manual valve to air actuation and have any doubts about which actuator and hardware you need, call our sales or technical staff for assistance.

### **i** ORDER TIP

To purchase a **valve with an air actuator installed**, go directly to valve ordering information.

### **➔** MORE INFO

Solenoid air valve for selectors . . . . . 180

### Mounting Hardware

Closemount hardware . . . . . page 190  
Right angle drive . . . . . 186  
Standoff assemblies . . . 187  
Standoff mounting hardware . . . . . 187



## AIR ACTUATORS FOR TWO POSITION VALVES

The recommended method for implementing a two position air actuator is a manifold solenoid valve assembly (MSVA2, page 180), a block-mounted pair of 3-way solenoids that pulses air to the actuator to switch it from position to position. If air is applied continuously, the continuous rotational force applied to the valve can cause sideloading, leaking, and additional wear.

Ideally, only enough air pressure should be used to switch the valve in 1/3 to 1/2 second. Bottled instrument air or nitrogen is recommended. If plant air from compressors must be used, an oil separator and water dryer are required.

A high speed switching accessory (HSSA) can upgrade valve switching times to less than 30 ms with air or 8 ms with helium. A position feedback (PFAF) with contact closures in both positions is also available as an option.

Typical actuation pressure is 40 to 50 psig, but up to 80 psig may be used.

### TECH TIP

Here's what you'll get when you order:



Air actuator with a closemount assembly



Air actuator with a 4" standoff assembly



Air actuator for use with an existing standoff

### MORE INFO

HSSA ..... page 182  
 High speed switching accessory  
 V-SV-S53 ..... 180  
 5-way three position solenoid air valve  
 PFAF ..... 181  
 Position feedback

### Standard air actuators

#### FOR TWO POSITION VALVES

Temperature range 0-70°C

Standoff version includes a 4" standoff. 2", 3", and 6" standoffs are also available.

			With closemount assembly	With 4" standoff assembly	For use with existing standoff
			Prod No	Prod No	Prod No
Number of ports in valve	3, 4	90° rotation	A90	A904	A90S
	6	60° rotation	A60	A604	A60S
	8	45° rotation	A45	A454	A45S
	10	36° rotation	A36	A364	A36S
	12	30° rotation	A30	A304	A30S

### High temperature air actuators

#### FOR TWO POSITION VALVES

Temperature range 50-175°C

Standoff version includes a 2" standoff. 3", 4", and 6" standoffs are also available.

			With closemount assembly	With 2" standoff assembly	For use with existing standoff
			Prod No	Prod No	Prod No
Number of ports in valve	3, 4	90° rotation	AT90	AT902	AT90S
	6	60° rotation	AT60	AT602	AT60S
	8	45° rotation	AT45	AT452	AT45S
	10	36° rotation	AT36	AT362	AT36S
	12	30° rotation	AT30	AT302	AT30S

### Replacement O-rings

Includes a complete set of O-rings for a two position air actuator.

	Prod No
Standard	OR
High temp	ORT



### Actuator compression fittings

#### FOR ALL AIR ACTUATORS

Includes 1/8" compression to 10-32 male thread, plus 1/8" brass ferrule and hex nut.

	Prod No
Standard	F-TCFB
High temp	F-TCF

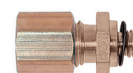

F-TCFB



F-TCF



**4-Way solenoid air valve**

FOR SELECTOR AIR ACTUATORS

This 4-way solenoid air valve with 1/8" tube fittings is the simplest method of stepping a selector air actuator. Energizing the solenoid steps the valve to its next position, and de-energizing the solenoid resets the mechanical ratchet in the actuator. This implementation, not recommended for two position actuators, can be useful when only a limited number of external events is available on the data system.

Prod No	
110 VAC	V-SV-S52-120VAC
240 VAC	V-SV-S52-240VAC
24 VAC	V-SV-S52-24VAC
24 VDC	V-SV-S52-24VDC

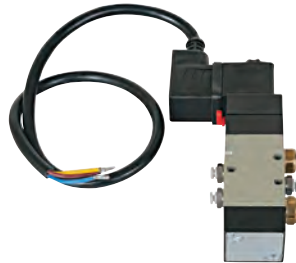

**3-Way solenoid air valve**

FOR DIAPHRAGM VALVES

This 3-way solenoid with 1/8" tube connections is perfect for switching spring-return valves such as our on/off or prime/purge valves (pages 198-199) or the DV23 diaphragm valves on page 124. Energizing the solenoid provides air to the actuator, while removing power from the solenoid allows the valve to return to its original state. Use of this solenoid is not recommended for rotary valves.

Prod No	
110 VAC	V-SV-S32-120VAC
240 VAC	V-SV-S32-240VAC
24 VAC	V-SV-S32-24VAC
24 VDC	V-SV-S32-24VDC



**5-Way 3 position solenoid air valve**

FOR TWO POSITION AIR ACTUATORS

This 5-way solenoid air valves with 1/8" tube connections is recommended to switch two position air actuators. It applies air to the actuator only during switching and alleviates problems associated with continuous air pressure.

Prod No	
110 VAC	V-SV-S53-120VAC
240 VAC	V-SV-S53-240VAC
24 VAC	V-SV-S53-24VAC
24 VDC	V-SV-S53-24VDC

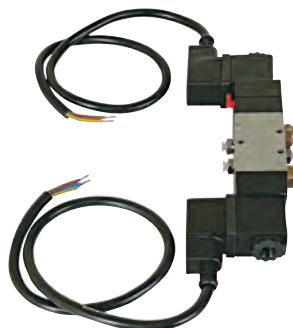

**MORE INFO**

**Actuators**

- Air ..... pages 178-179
- Microelectric ..... 176
- Universal electric ..... 174-175

**Mounting Hardware**

- Closemount hardware ..... page 190
- Right angle drive ..... 186
- Standoff assemblies .. 187
- Standoff mounting hardware ..... 187

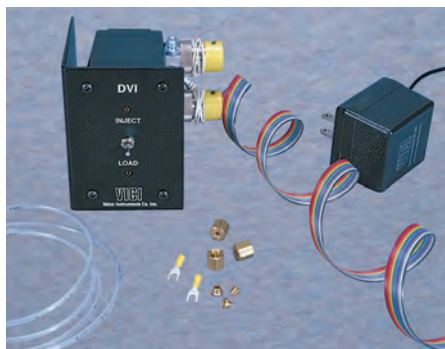

**DVI Digital valve interface (NON-CE) FOR TWO POSITION AIR ACTUATORS**

We highly recommend the DVI for use with two position air actuators. It sends a two second pulse of air to switch the valve and then vents the air, simulating switching by hand and eliminating the potential for damaging the valve or actuator with continuously-applied pressure. It also features LED position indication, manual and remote operation, and a contact closure output on arrival to the INJECT position, a feature which can be used to start a run or integration. The DVI is available for 110 or 230 VAC.

Prod No	
110 VAC	DVI
230 VAC	DVI-220

**Position feedback FOR TWO POSITION AIR ACTUATORS**

The optional position feedback (PFAF) can be field installed on any two position standard air actuator. Each position provides a contact closure for TTL logic level signals.

Prod No
PFAF



**Position feedback FOR MANUAL VALVES**

An optional position feedback is available for manual Valco W type and Cheminert C2 and C4 series valves (standard on Cheminert C1 valves). The continuous contact closure, provided only while the valve is in the inject position, can be used to start a chromatograph or data system.

Prod No		
For Valco W type valves	4 port	PFW90
	6 port	PFW60
	8 and 10 port	PFW36
For Cheminert valves	C2 series except 4 port *	PFC2
	C2 series, 4 port *	PFC4
	C4 series	PFC4

\* Can also be used with C22 series.



**➔ MORE INFO**  
 Valco W type valves . . . . . page 96  
 Cheminert valves  
 C2 series. . . . . 140, 144  
 C4 series. . . . . 141, 145  
 C22 series . . . . . 149



## High speed switching accessory FOR TWO POSITION AIR ACTUATORS

The HSSA is an add-on for our standard air actuators, providing increased air or helium flow for the fast actuation required in microbore chromatography or partial loop injections. Normal switching time for a C6W with 100 psi air is 180 ms. With the HSSA that drops to 20 ms; substitute 100 psi helium and the valve switches in 8 ms. Usually the HSSA is used in conjunction with the DVI on the preceding page.

Prod No

HSSA



## PURGE HOUSINGS

The purpose of any purging method is to eliminate diffusion from the atmosphere into the valve, or to safely vent fugitive emissions from the valve. This is best accomplished with our *internal* purge design, now available in many Valco two position valves and multiposition selector valves. These designs have the purge fittings machined into the valve body, so the valve is as easy to use and maintain as non-purged versions.

However, there are some valves which will not readily accommodate the internal purge design. In these instances, the older *external* purge housing (shown below) can be used. This housing can be retrofitted to existing valves if they have two threaded mounting holes through the valve body. For existing valves without these mounting holes, it is more economical to purchase a new valve with the internal purge feature built in.

Field installation of the purge housing is typically not recommended.

Please call our service department for information and pricing to have a purge housing factory-installed on your existing valve. The purge housing requires an integral standoff assembly, which must be ordered with the housing.

*Note:* The purge housing limits the maximum temperature of the purged valve to 175°C, regardless of the valve specifications.

The internal purge is available on UW type valves with 1/16" fittings. See two position listings on page 87 for availability. Most Valco low pressure selectors on pages 104-113 are available with a built in purge option. Our technical support staff can provide specifics regarding availability and cost.



### **i** INTERNALLY PURGED VALVES

Contact the factory for information on internally purged valves which are not on pages 86-87.





**HEATED VALVE ENCLOSURE**

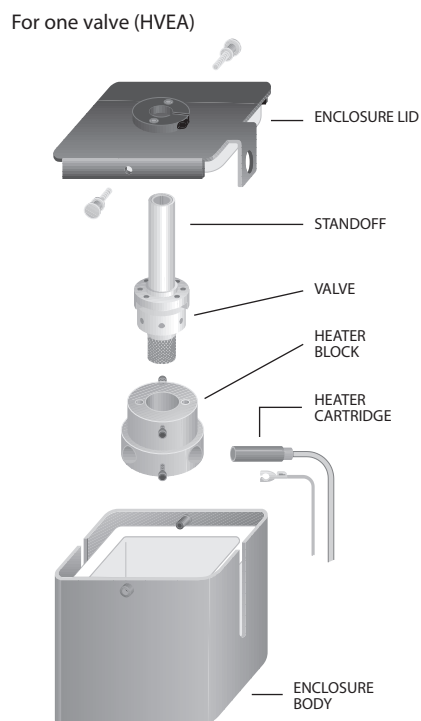

**HEATED VALVE ENCLOSURES**

These insulated enclosures allow valves to be operated at temperatures independent of other controlled zones of analytical instruments. The compact construction and minimum power dissipation enable mounting within larger, lower temperature zones without significantly raising the larger oven's minimum temperature or impairing its programmability.

All enclosures include a heater block and a heater cartridge with line cord. The product number chart lists the heater size typically required to heat the valve(s) to the indicated temperature. Holes are provided in the heater block for Perkin Elmer, Agilent, and other temperature sensors, with an additional thermocouple hole permitting

temperature readout. Since 1/32" W type valves are smaller, they require a special heater block; enclosures for 1/32" valves are denoted by asterisk (\*) in the price chart below.

**Note:** Heated valve enclosures provide a way to heat valves. A GC's auxiliary temperature zone controller or a device such as our ITC (instrumentation temperature controller) is required to maintain the valves at a set temperature.

Includes insulated enclosure and heater assembly (standard heater block, heater cartridge, line cord). Standard voltage: 110 VAC. For a 230 VAC model, add -220 to the product number. Insulation is 1/2" thick, so internal dimensions are 1" smaller than the exterior size given below.

**Heated valve enclosures (NON-CE) FOR TWO POSITION VALVES AND SELECTORS**

Capacity	Exterior dimensions (Interior approx 1" smaller)	Rating	With heater cartridge*	Without heater cartridge
			Prod No	Prod No
1 valve	4" x 4-1/4" x 3-5/8"d	65W/350°C	HVEA	HVEAX
		65W/350°C **	HVEAN	HVEANX
	4-1/4" x 5-1/8" x 3-5/8"d	65W/350°C	HVEB	HVEBX
		65W/350°C **	HVEBN	HVEBNX
	8" x 8" x 6"d	100W/350°C	HVEC	HVECX
2 valves	8" x 5-1/4" x 4"d	125W/350°C	HVE2	HVE2X
3 valves	13-1/2" x 5-3/4" x 4"d	150W/350°C	HVE3	HVE3X
6 valves	13-3/4" x 8" x 6"d	300W/350°C	HVE6	HVE6X

\* Heater cartridges are not CE-certified

\*\* For use with 1/32" valves

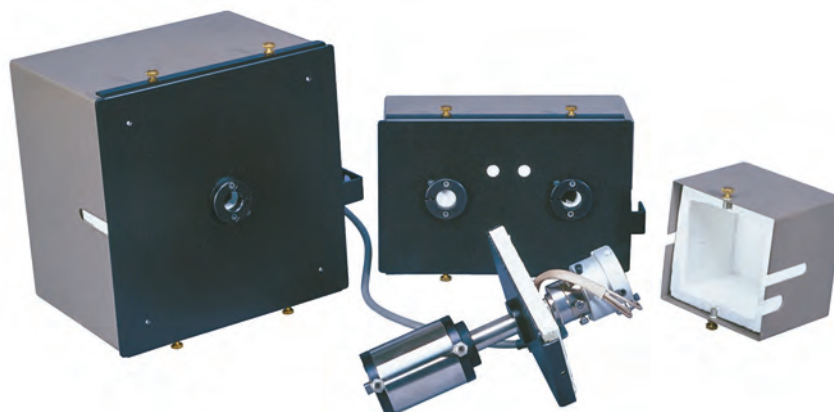

**MORE INFO**

ITC ..... page 185  
Instrumentation  
temperature controller

Heated column  
enclosures.....185  
Heater assemblies ... 184  
Heater blocks..... 184  
Heater cartridges.... 184



**Heater assemblies**

A heater assembly includes a standard heater block, heater cartridge, and line cord. Heater cartridges are also available individually. Consult the factory for price and availability.

Standard voltage is 110 VAC. For a 230 VAC model, add -220 to the product number.

	<i>Rating</i>	<i>Prod No</i>
For use with HVEA or HVEB	65W/350°C	HA1
For use with HVEC	100W/350°C	HA1T
For use with HVE2	125W/350°C	HA2
For use with HVE3	150W/350°C	HA3
For use with HVE6	300W/350°C	HA6

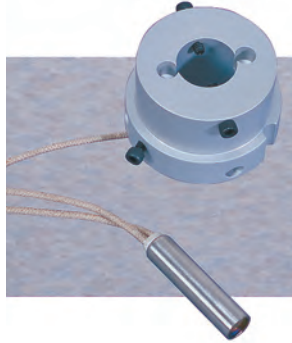

**Heater blocks**

**FOR SINGLE VALVES**

There are two single valve heater block designs: standard and low mass. The low mass heater block, which has a .075" diameter hole for sensor or thermocouple, works well for two position valves. The standard heater block is a high mass, multipurpose design which can be used with any Valco valve. It is designed so that sample loops or short columns can be wound directly on it.

Heater blocks do not include a heater cartridge.

		<i>Prod No</i>
1 valve	Low mass heater block	HBS
1 valve	Standard heater block	HB
1 valve, 1/32" Valco	Standard heater block	HB1N



**Heater cartridges**

**FOR SINGLE VALVE HEATER BLOCKS**

The cartridge size is 1.5" long by 3/8" diameter. Consult the factory to purchase cartridges for larger heater blocks.

<i>Rating</i>	<i>Prod No</i>
65W, 110 VAC	I-21208-32
65W, 220 VAC	I-21208-33
100W, 110 VAC	I-21208-05
100W, 220 VAC	I-21208-06



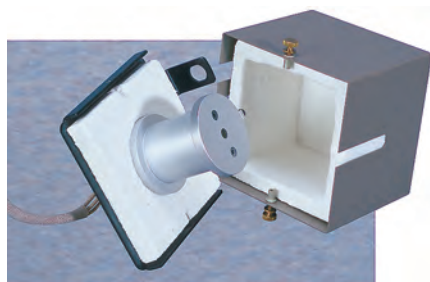

## Heated column enclosures

(NON-CE)

Heated column enclosures allow a column to be operated at temperatures independent of other controlled zones in the instrument. They are similar in construction to our heated valve enclosures (*page 183*), except instead of a valve heater block they contain a column mandrel which will accept 1/8" columns up to 10' long. The HCE2 can have a heated valve installed adjacent to the heated column, with a valve heater block ordered separately.

Includes one column mandrel, insulated enclosure, and heater assembly (standard heater block, heater cartridge, line cord). Standard voltage: 110 VAC. For a 230 VAC model, add -220 to the product number. Insulation is 1/2" thick, so internal dimensions are 1" smaller than the exterior size given below.

Capacity	Exterior dimensions (Interior approx 1" smaller)	Rating	With heater cartridge*	Without heater cartridge
			Prod No	Prod No
1 column	4" x 4-1/4" x 3-5/8"d	65W/350°C	HCE1	HCE1X
	4-1/4" x 5-1/8" x 3-5/8"d	65W/350°C	HCEB	HCEBX
	8" x 8" x 6"d	100W/350°C	HCEC	HCECX
2 columns	8" x 5-1/4" x 4"d	125W/350°C	HCE2	HCE2X
Column mandrel (heater assembly not included with column mandrel)			CM	

\* Heater cartridges are not CE-certified



## ITC Instrumentation temperature controller

(NON-CE)

The ITC is an isothermal proportional controller for use in the thermal systems common to analytical instrumentation, and is often used with heated valve enclosures. The desired temperature is set in 1°C increments on the front panel. A thermocouple sensor provides quick recognition of temperature changes. The power to the heater can be attenuated from 0-90% in 10% increments, an easy-to-use feature which improves temperature stability at the set point to 0.5°C. Maximum output current is 10 amps.

The ITC is available with a range of 0°C to 399°C, in 110 VAC or 230 VAC.

Prod No		
0°C to 399°C	110 VAC	ITC10399
	230 VAC	ITC10399-220
Replacement thermocouple	I-21014-01	

### ➔ MORE INFO

Temperature Programmer  
for Fast GC . . . . . page 204



**Knobs and handles**

FOR USE WITH A STANDOFF

If you already have a spare standoff assembly (see facing page) but lack the knob or retainer, or have an actuated valve on a standoff which you'd like to convert to manual use, here's what you'll need. Includes knob or handle, retainer, and adapter.

Prod No

Knob for a W type valve	WMMASO
Knob for a W/UW type valve	SOMAW
T-handle for a UW type valve	SOUTH
Handle for a UW type valve	SOMAP
Handle with position feedback for a W/uw type valve	SOMAPPF

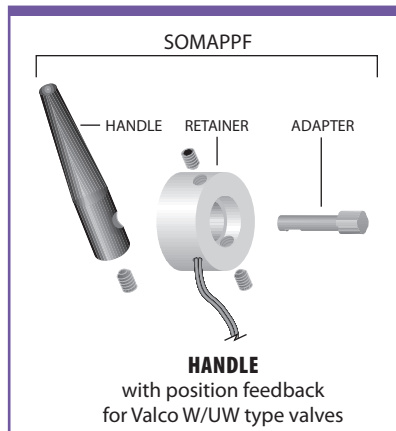
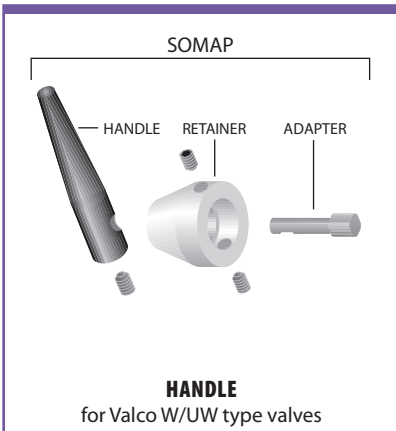
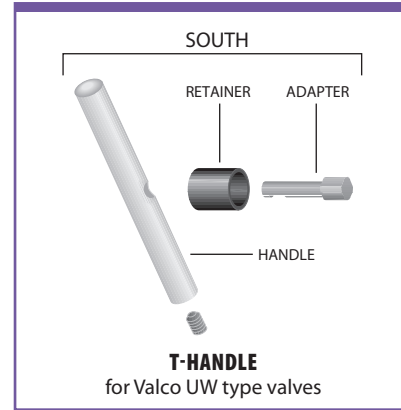
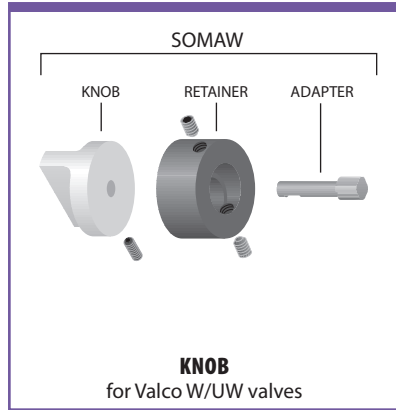
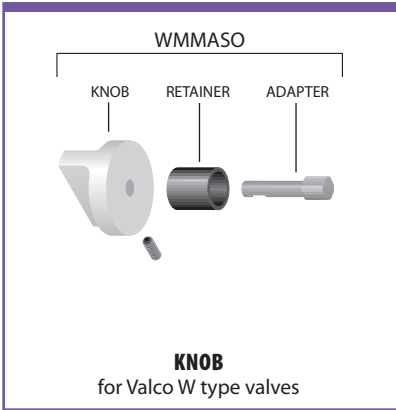

**RAD Right angle drive**

FOR TWO POSITION ACTUATORS

Some installations don't work so well with the valve and actuator installed in the typical in-line configuration. The right angle drive is a 90° gearbox which permits the actuator or handle to be installed at a right angle to the valve.

The RAD fits all VICI two position electric and air actuators, but it cannot be used with valves with 1/4" fittings.

Because the RAD works with a variety of actuators and valves, the proper mounting hardware must be ordered separately.

Consult the factory for help with your application.



**t TECH TIP**

RADs add a slight amount of backlash and load. The backlash is not an issue with two position valves on microelectric or universal actuators, since the actuators locate and remember the stopping point. However, for two position valves on other actuators and for all selectors, we recommend that the valves have ports no smaller than .016".

The additional load may mean that a valve that ordinarily requires an ED actuator might require an ET when used with a right angle drive.

If you have any questions, please consult our technical support.



## STANDOFF ASSEMBLIES

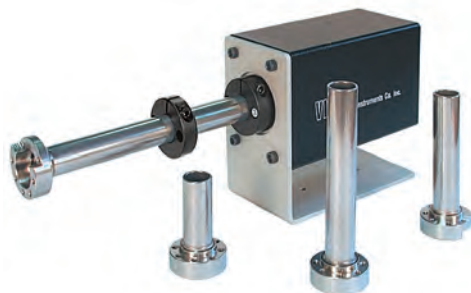

Valves which will be installed in ovens or heated zones require a standoff assembly, which locates the actuator out of the heated zone and supports both the valve and the handle or actuator. The 5/8" outside diameter standoff tube extends through the oven wall and is secured by means of a clamp ring supplied with the assembly.

If you are converting an actuated valve from a closemount to a standoff application, order the appropriate clamp ring and two screws in addition to the standoff assembly. Consult the factory for availability of non-standard lengths.

Selectors on universal actuators use a special standoff assembly (SOMMP) which is keyed to both valve and actuator. The key guarantees proper alignment and positioning of the valve.

Product numbers show the most common length of standoffs: 4" for air actuators and manual knobs, 2" for electric actuators. Standoff assemblies are available in lengths of 2", 3", and 6". To order a 6" standoff instead of a 4" one, change the 4 at the beginning of the product number to a 6.

### Standoff assemblies and mounting hardware

FOR ACTUATORS

		Standoff assembly Prod No	Clamp ring Prod No	Screws Prod No
<b>Air actuators</b>				
For Valco two position valves	with 1 or 2 mounting holes	4SOA	CR3	HWSC-SC8-6
	with no mounting holes	4SOAMP	CR3	HWSC-SC8-6
For Valco selectors		4SOAMP	CR3	HWSC-SC8-6
For Cheminert valves		4SOAMP	CR3	HWSC-SC8-6
<b>Microelectric actuators</b>				
For Valco two position valves	with 1 or 2 mounting holes	2SOA	CR8	HWSC-SC8-8B
	with no mounting holes	2SOAMP	CR8	HWSC-SC8-8B
For Valco selectors		2SOAMMP	CR10	HWSC-SC8-6TDH
For Cheminert two position valves		2SOAMP	CR3	HWSC-SC8-8B
For Cheminert selectors		2SOAMMP	CR10	HWSC-SC8-6TDH
<b>Universal actuators</b>				
For Valco two position valves	with 1 or 2 mounting holes	2SOA	CR8	HWSC-SC8-8B
	with no mounting holes	2SOAMP	CR8	HWSC-SC8-8B
For Valco selectors		2SOAMMP	CR10	HWSC-SC8-6TDH
For Cheminert two position valves		2SOAMP	CR3	HWSC-SC8-8B
For Cheminert selectors		2SOAMMP	CR10	HWSC-SC8-6TDH

#### TECH TIP

If you need the **actuator as well as the hardware**, you can order it complete with the appropriate hardware or with the required standoff already installed.

#### Actuators

Air . . . . . pages 178-179  
Microelectric . . . . . 176  
Universal elec . . . 174-175

#### CONVERTING FROM CLOSEMOUNT TO STANDOFF

If you are converting an actuated valve from a closemount to a standoff application, the clamp ring and screws which secure the standoff to the actuator are **not included** in the standoff assembly. Order clamp ring and screws in addition to the standoff assembly.

#### MORE INFO

For illustrations of standoffs on valves and actuators, see pages 188-189.

### Standoff assemblies

FOR MANUAL VALVES

Includes knob, standoff assembly, retainer, and adapter. For illustration, see page 186.

		Prod No
For Valco W/UW two position valves rated <5000 psi	with 1 or 2 mounting holes	4SOWK
	with no mounting holes	4SOWKMP
For Valco UW two position valves rated >5000 psi	with 1 or 2 mounting holes	4SOUTH
	with no mounting holes	4SOUTHMP
For Cheminert valves		4SOWKMP



# Standoff assemblies



## ACTUATORS AND ACCESSORIES

### STANDOFF – VALCO TWO POSITION VALVE – MANUAL

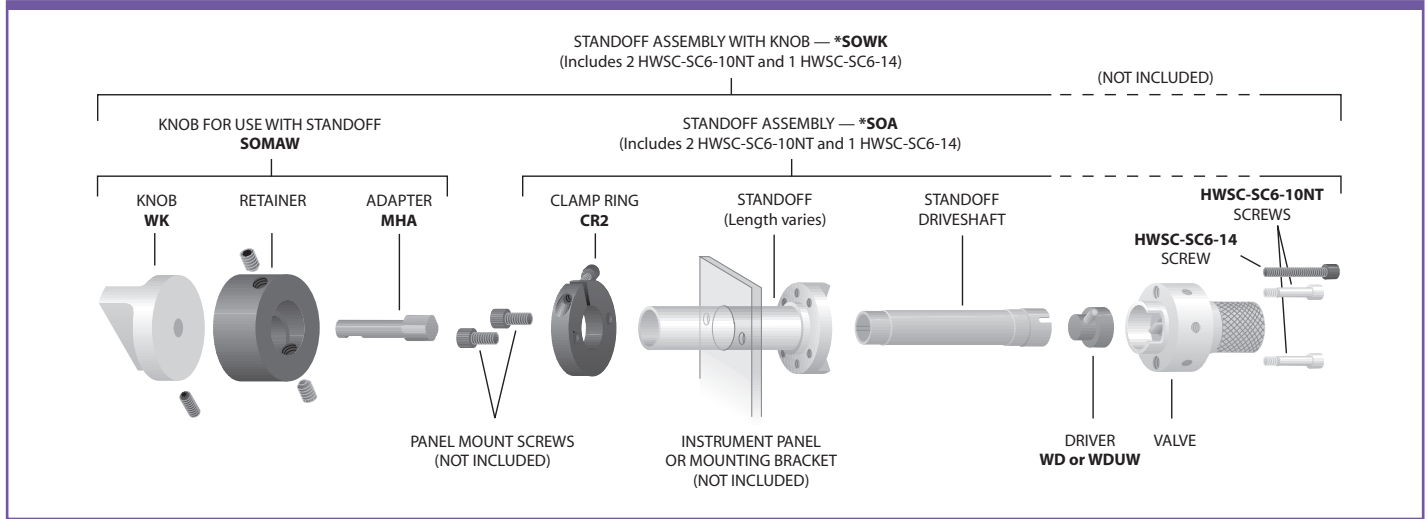

### STANDOFF – VALCO TWO POSITION VALVE – AIR ACTUATOR

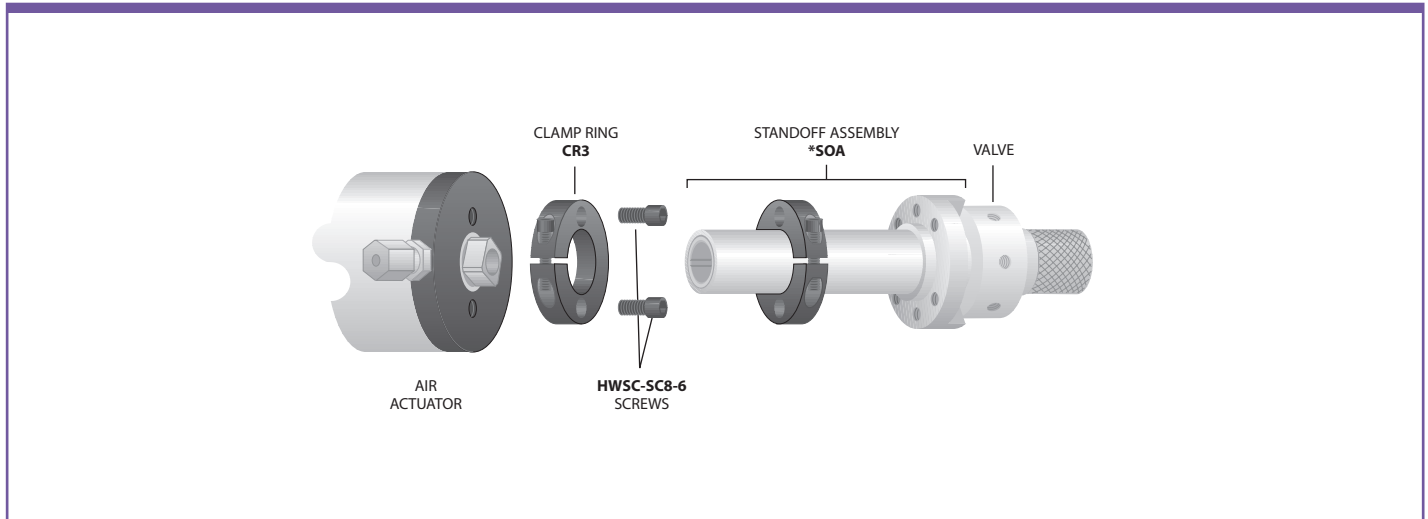

### STANDOFF – VALCO SELECTOR – AIR ACTUATOR

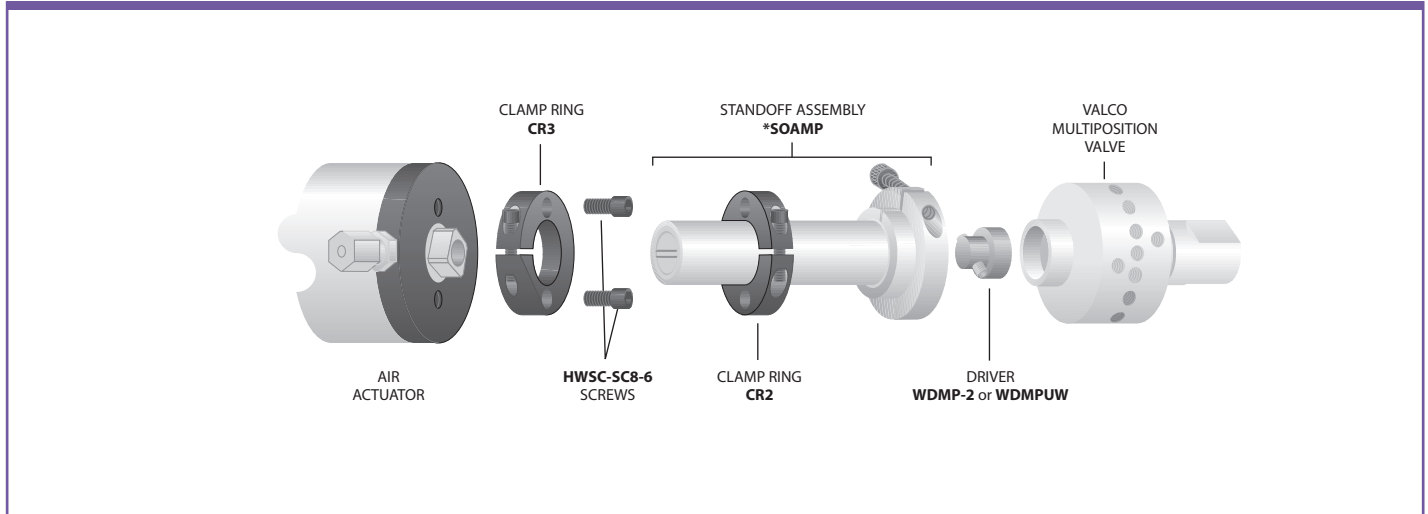



**KEYED STANDOFF – VALCO SELECTOR – UNIVERSAL OR MICROELECTRIC ACTUATOR**

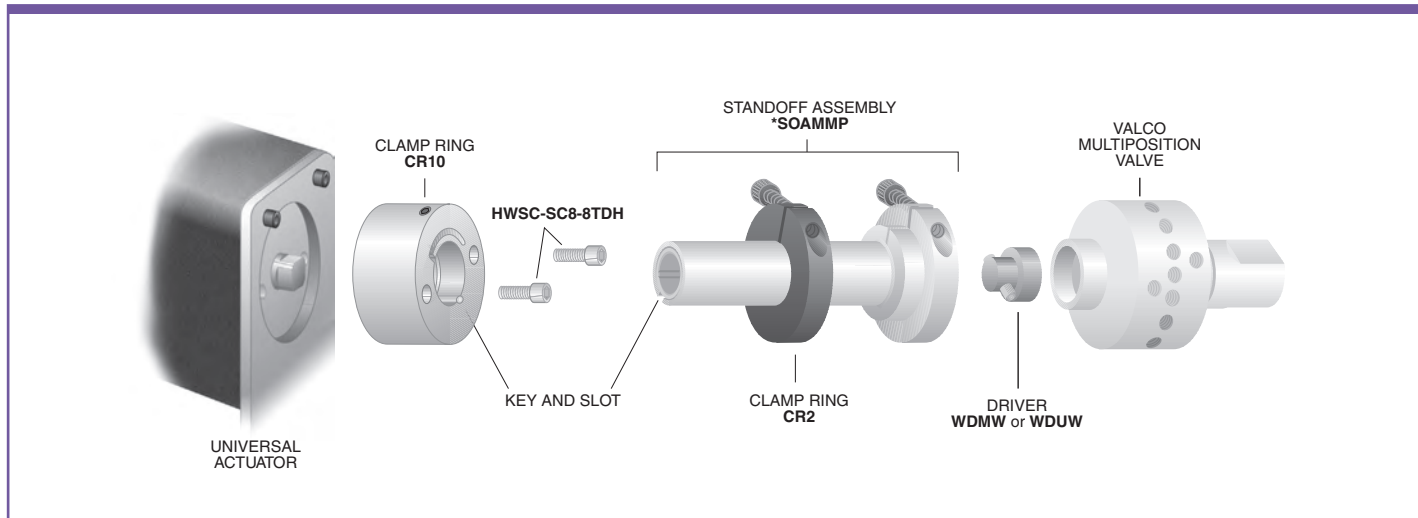

**STANDOFF – CHEMINERT TWO POSITION VALVE – MANUAL**

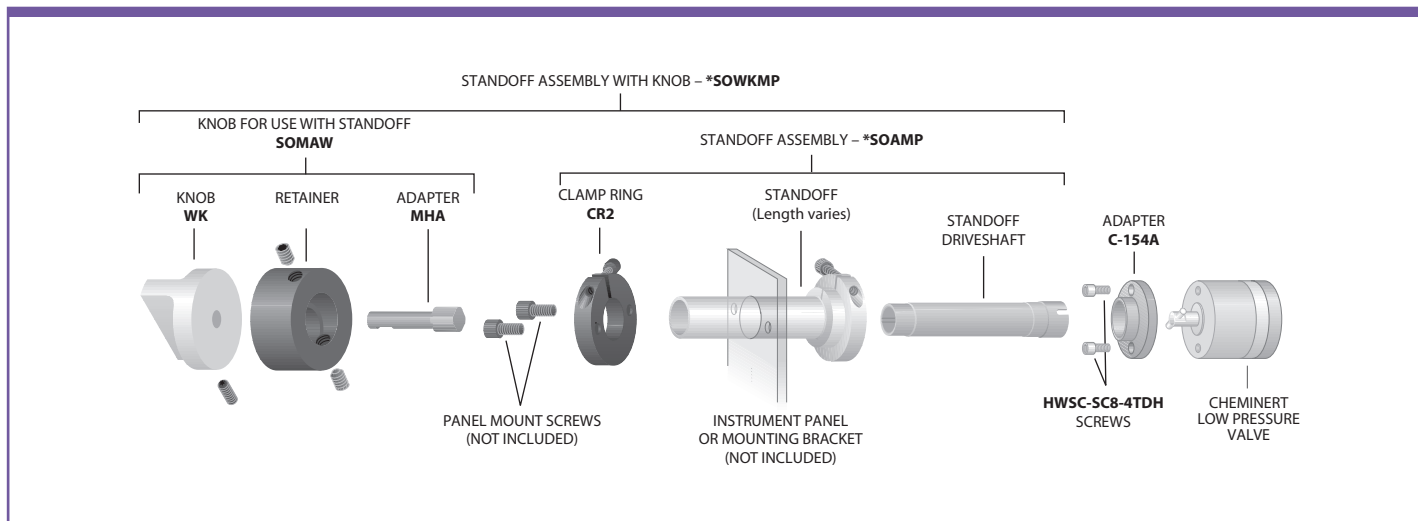

**KEYED S STANDOFF – CHEMINERT SELECTOR – UNIVERSAL OR MICROELECTRIC ACTUATOR**

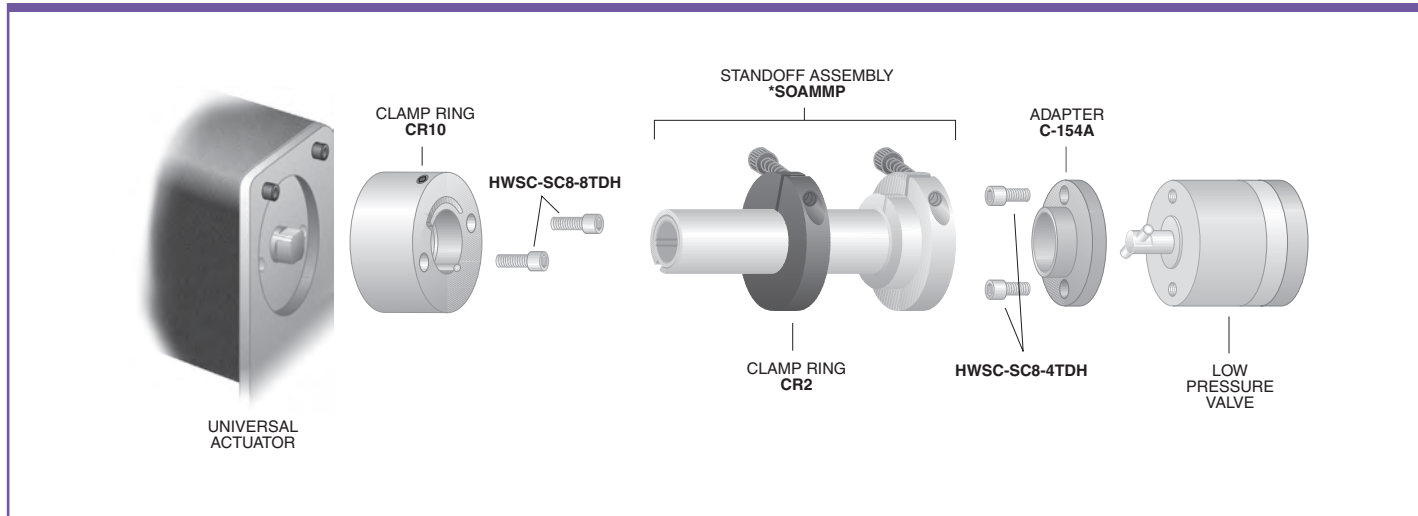



**CLOSEMOUNT HARDWARE**

If a valve is not going to be heated beyond the temperature range of the actuator, closemount hardware often makes the cleanest installation.

**Closemount hardware FOR MANUAL VALVES**

If you have a Valco W Type valve with no hardware and want a knob on it, or if you are converting an air or electrically actuated two position valve to manual use, this is what you need. There are two versions: one for valves with threaded mounting holes and one for valves with unthreaded mounting holes. (If your valve has no mounting holes, you will have to use it with a standoff.)



		<i>Prod No</i>
For valves with	threaded mounting holes	WMMA
	unthreaded mounting holes	WMMA10

**Closemount hardware FOR ACTUATORS**

Order the appropriate closemount hardware if you want to change your valve and actuator from a standoff to a closemount connection. Two mounting screws are included. If air and standard electric actuators require different mounting screws, two of each screw are included with the closemount hardware.



		<i>Prod No</i>
<b>Air actuators</b>		
For Valco two position valves	with 1 or 2 mounting holes	CMH
	with no mounting holes	CMHMP
For Valco selectors		CMHMP
For Cheminert valves	high pressure	CMH11H
	low pressure <i>(includes required adapter)</i>	CMH11L
<b>Universal and microelectric actuators</b>		
For Valco two position valves	with 1 or 2 mounting holes	CMH12H
	with no mounting holes	CMH12H
For Valco selectors (UW and MW type)		CMH13
For Cheminert two position valves	high pressure	CMH12H
	low pressure <i>(includes required adapter)</i>	CMH12L
For Cheminert selectors	high pressure	CMH13H
	low pressure <i>(includes required adapter)</i>	CMH13L

**t TECH TIP**

If you need the **actuator as well as the hardware**, you can order it complete with the appropriate hardware or with the required standoff already installed.

**Actuators**

Air . . . . . pages 178-179  
 Microelectric . . . . . 176  
 Universal elec . . . 174-175



**CLOSEMOUNT – VALCO VALVE – MANUAL**

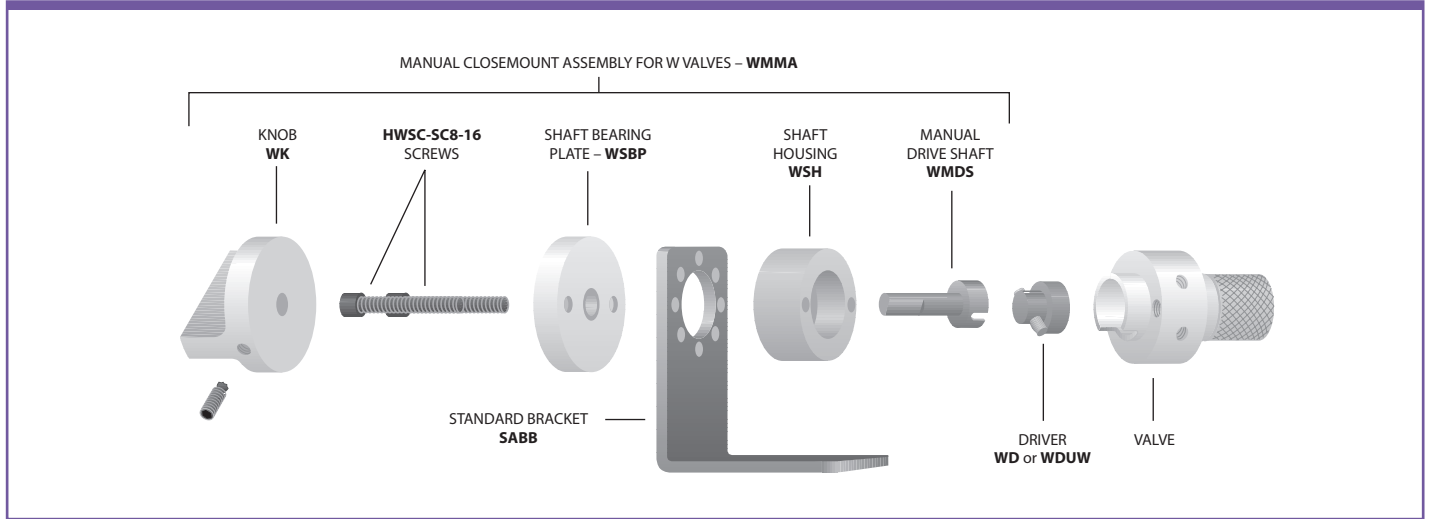

**CLOSEMOUNT – CHEMINERT VALVE (Low pressure two position) – UNIVERSAL OR MICROELECTRIC ACTUATOR**

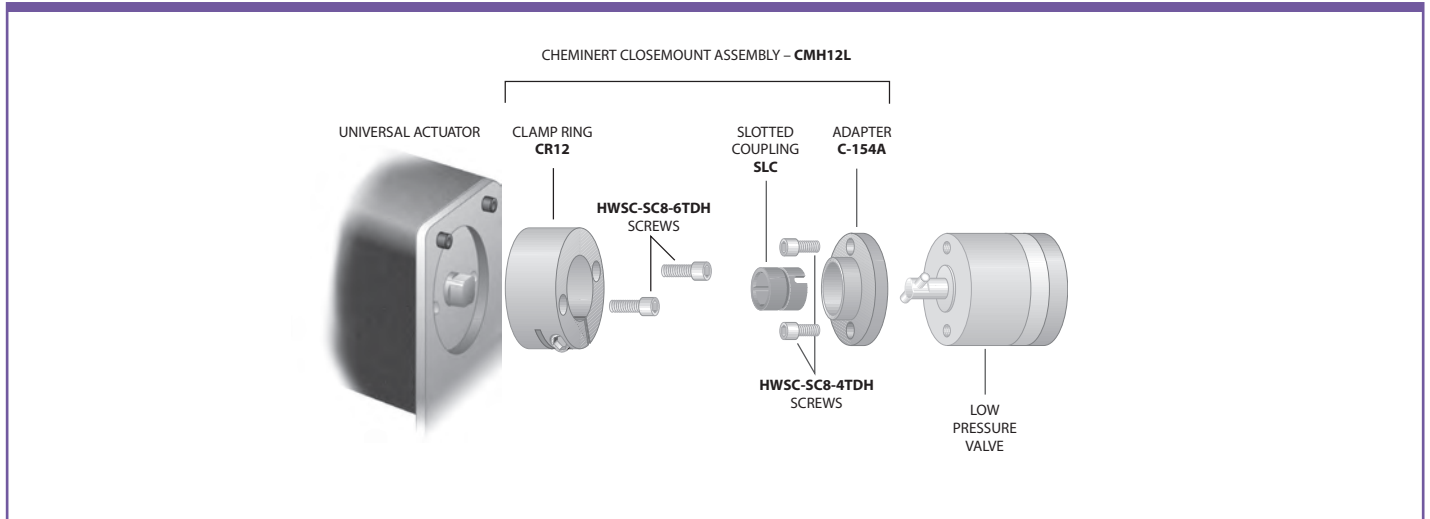

**CLOSEMOUNT – VALCO VALVE (1 or 2 mounting holes) – AIR ACTUATOR**

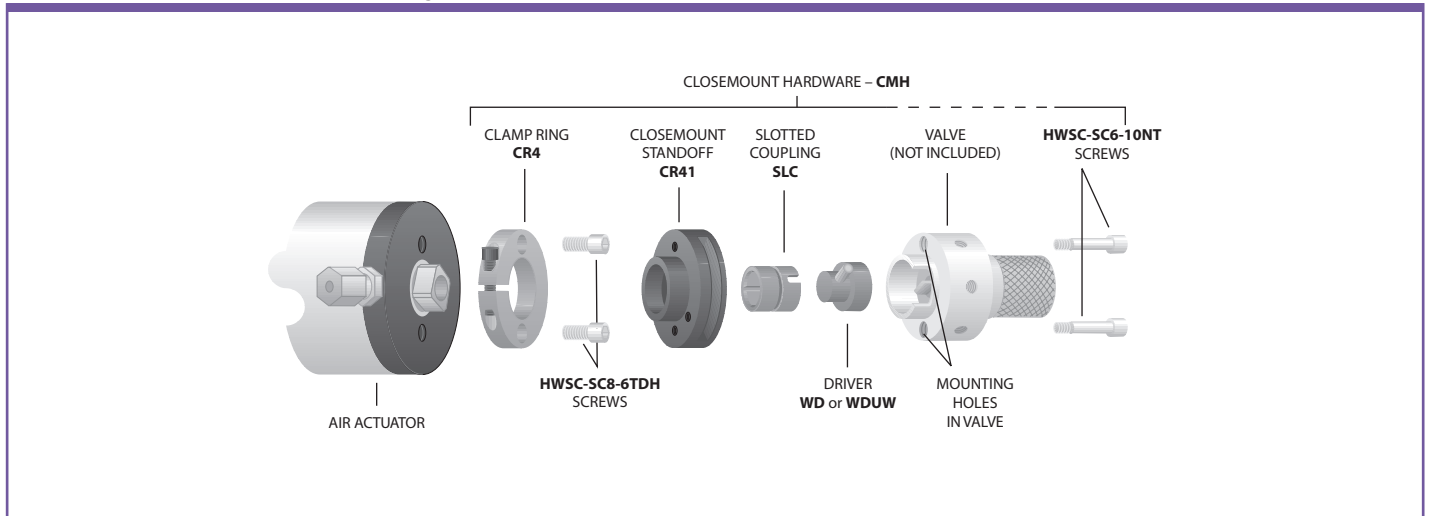

## Tools



### ACTUATORS AND ACCESSORIES

As a convenience to our customers, we stock several standard tools that are useful for working with valves, fittings, and other products from VICI. In addition, we offer custom tools which are designed and machined in our factory to facilitate use of specific VICI products.

### Custom socket wrench

These socket wrenches with a slot to slip over the tubing are the perfect tool for installing fittings when proximity of the ports makes it difficult to get a normal open end wrench in position. The SWH3 fits the 3/16" hex head on our 1/32" ZDV fittings; the SWH4 works with the 1/4" hex nuts for 1/16" fittings.

	<i>Prod No</i>
3/16"	SWH3
1/4"	SWH4

Call for a quote.



### Hex key set

The hex key set has a wrench to fit any socket head screw on any VICI valve or actuator. Includes .050", 1/16", 5/64", 3/32", 7/64", 1/8", 9/64", and 5/32" sizes.

<i>Prod No</i>
HKS



### Open end wrenches

	<i>For use with</i>	<i>Prod No</i>
3/16" x 1/4"	1/32" and 1/16" nuts	OEW
3/8" x 7/16"	1/8" nuts	OEW-2
1/2" x 9/16"	1/4" nuts	OEW-3



### Pencil magnet

A pencil-type magnet is useful for removing the rotor from Valco valves when the rotor must be replaced or rotated. The process of disassembly and assembly is described in Technical Note 201, which may be found in the support section at [www.vici.com](http://www.vici.com).

<i>Prod No</i>
PM



**MORE INFO**

Ferrule removal kit . . . p 41



### Pin vise and drill index

The drill index has drills sized from 0.0135" to 0.039" (0.34 to 1 mm). These are useful tools when a fused silica tube breaks in a union, or for enlarging the inner diameter of fused silica adapters.

Prod No

PV

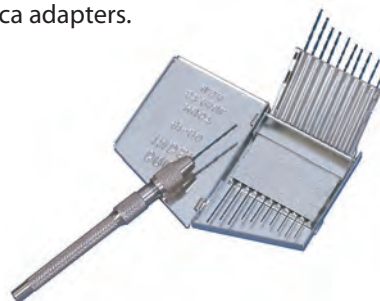

### Template

This tool is useful for working out plumbing and valve switching schematics. It features templates for two position valves with 4, 6, 8, and 10 ports with indications of both positions, as well as various flow symbols. For added convenience, the sides are edged with metric and inch rulers.

Prod No

TEMPLATE1

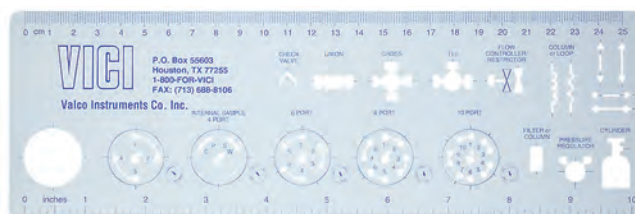

### Valve spanner handle

A special tool for gripping a multiposition valve body. It is especially useful during valve alignment procedures.

Prod No

VSH



### Mirror

Helpful to get access to valve serial numbers and to check discharge on pulsed discharge detectors (PDD).

Prod No

MR

